



**DIRECT-REPLACEMENT
INSTALLATION GUIDE**

FORD SUPERDUTY (2017-ON)

PERFORMANCE ELITE SERIES 2.5 DUAL SPEED COMPRESSION

883-26-095 - Kit: 17-On Ford SD Front, 2.5 Truck PES, R/R, 0-1.5" Lift, DSC
883-26-096 - Kit: 17-On Ford SD Rear, 2.5 Truck PES, P/B, 0-1.5" Lift, DSC
883-26-097 - Kit: 17-On Ford SD Front, 2.5 Truck PES, R/R, 2-3.5" Lift, DSC
883-26-098 - Kit: 17-On Ford SD Rear, 2.5 Truck PES, P/B, 2-3.5" Lift, DSC
883-26-099 - Kit: 17-On Ford SD Front, 2.5 Truck PES, R/R, 4-6" Lift, DSC
883-26-100 - Kit: 17-On Ford SD Rear, 2.5 Truck PES, P/B, 4-6" Lift, DSC

CONTENTS

INTRODUCTION	1
SUPPLIED PARTS	2
SHOCK DIAGRAM	3
SAFETY INSTRUCTIONS	4
INSTALLATION GUIDELINES	5
FRONT SHOCK INSTALLATION	6
REAR SHOCK INSTALLATION	10
FOX FACTORY DSC	11
WARRANTY INFORMATION	12
SHOCKS NEED LOVE TOO	13

INTRODUCTION

Thank you for choosing FOX direct replacement, shocks for your vehicle. FOX products are designed, tested, and manufactured by the finest professionals in the industry.

FOX recommends that you become completely familiar with the handling characteristics of your modified vehicle before operating it under rigorous conditions, helping to avoid potential rollover situations and other loss of control events. FOX further recommends that you use appropriate protective equipment at all times when operating your vehicle.

To achieve the best performance and product longevity, periodic service and maintenance is required. Please refer to the Service and Upgrades section for more information.

IN THE BOX

- Mounting Hardware
- Reservoir Mounts
- Front Shocks
- Rear Shocks
- Installation Guide

SUPPLIED PARTS

SHOCK ASSEMBLY				
FOX PN	DESCRIPTION		QTY	NOTES
983-26-095	FRONT, LEFT/RIGHT SHOCK		2	0-1.5" LIFT
983-26-096	REAR, LEFT/RIGHT SHOCK		2	
983-26-097	FRONT, LEFT/RIGHT SHOCK		2	2-3.5" LIFT
983-26-098	REAR, LEFT/RIGHT SHOCK		2	
983-26-099	FRONT, LEFT/RIGHT SHOCK		2	4-6" LIFT
983-26-100	REAR, LEFT/RIGHT SHOCK		2	
FRONT RESERVOIR BRACKET ASSEMBLY				
FOX PN	DESCRIPTION	*HARDWARE REF.	QTY	NOTES
026-01-206-1	DRIVER SIDE, RESERVOIR MOUNT	A	1	Brackets mount the front reservoirs to the vehicle.
026-01-206-2	PASSENGER SIDE, RESERVOIR MOUNT	B	1	
018-01-049	SCREW: 1/4"-14 X 3/4" HEX HEAD, SELF-TAPPING	C	2	Each bracket uses one self-tapping screw.
018-01-066	SCREW: 8-32, 3/4"	D1	4	Each bracket uses two clamps and a clamp uses two screws.
026-01-167-1	2.5 RESERVOIR CLAMP, TOP	D2	2	
026-01-167-2	2.5 RESERVOIR CLAMP, BOTTOM	D3	2	

*Hardware Reference is used throughout the installation manual to provide notation of the supplied kit.

SHOCK DIAGRAM

FRONT SHOCK

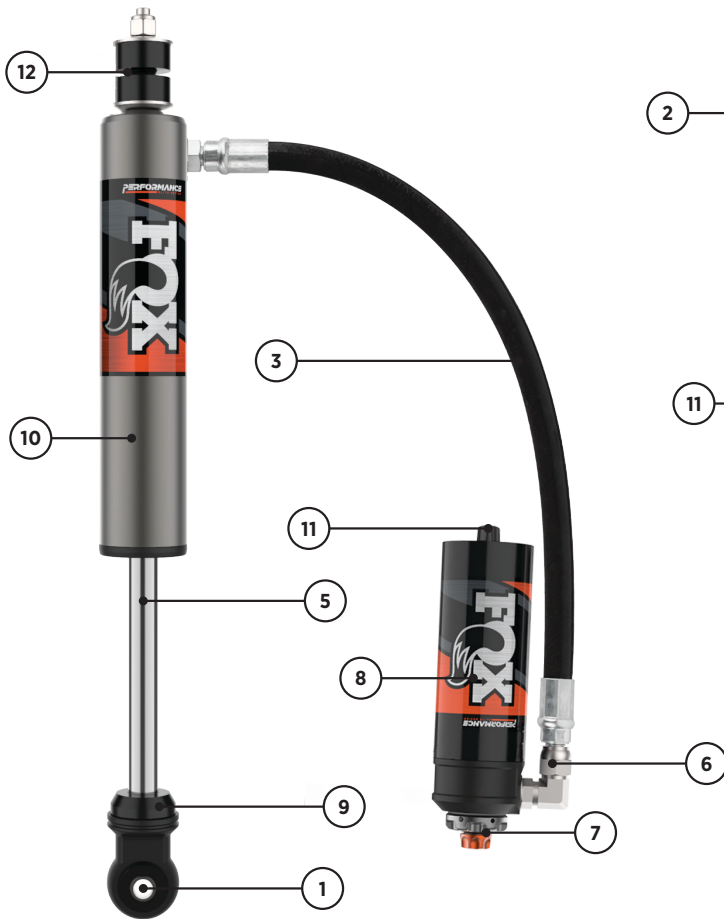

REAR SHOCK

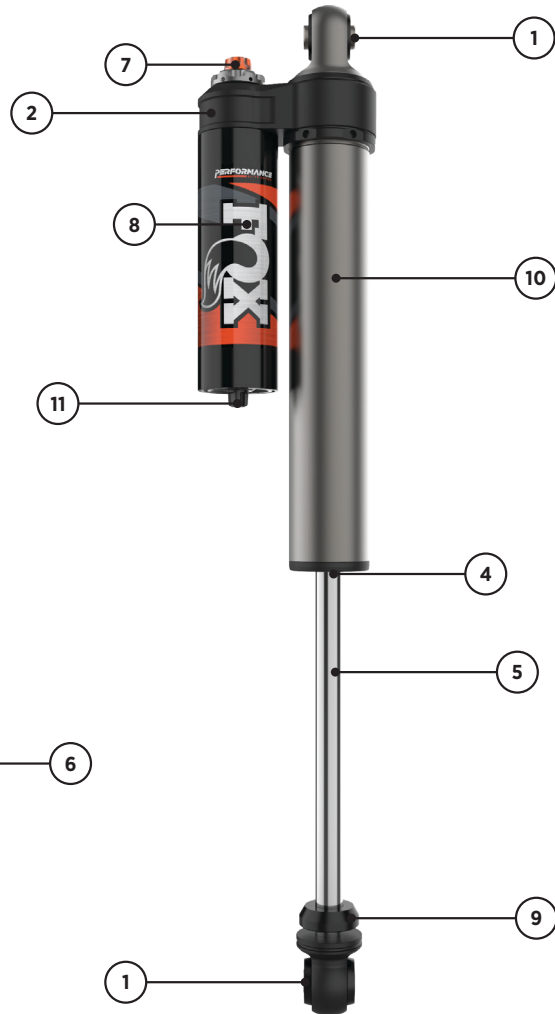

PART NO.	NAME	PART NO.	NAME
1	Eyelet	7	DSC adjuster
2	Reservoir bridge	8	Reservoir
3	Hose	9	Bumpstop
4	Wiper seal	10	Shock body
5	Shaft	11	Schrader Valve
6	Hose coupler	12	Stem

WARNING

SAFETY INSTRUCTIONS

- FOX direct-replacement shocks are designed to fit and allow proper clearance with the stock suspension. If aftermarket suspension components are installed it is the customer's responsibility to ensure that interference between the FOX shocks and other vehicle components does not occur at any point in the shock stroke.
- FOX direct-replacement shocks should always be installed as a set for maximum performance.
- Proper installation and service procedures are essential for the safe and reliable operation of the suspension components, requiring the experience and tools specially designed for this purpose. Installation and maintenance procedures for this product must be performed by a qualified service technician, to avoid potentially unsafe vehicle handling characteristics, which may result in **SERIOUS INJURY** or **DEATH**.
- Modifying your vehicle's suspension will change the handling characteristics of your vehicle. Under certain conditions, your modified vehicle may be more susceptible to loss of control or rollover, which can result in **SERIOUS INJURY** or **DEATH**. Thoroughly familiarize yourself with the modified vehicle handling characteristics before any rigorous vehicle operation. Wear protective body gear and a helmet when appropriate. Installation of vehicle roll bars or cage is highly recommended.
- FOX direct-replacement shocks are gas-charged and are highly pressurized. Placing shocks in a vise or clamp, applying heat, or attempting to open or service the shock without the proper tools and training can result in **SERIOUS INJURY** or **DEATH**. Do not attempt to modify, puncture or incinerate a FOX direct-replacement shock absorber.
- Any attempt to misuse, misapply, modify, or tamper with any FOX product voids any warranty and may result in **SERIOUS INJURY** or **DEATH**.

WARNING

INSTALLATION GUIDELINES

- Always use a chassis lift for the installation of shocks, and make certain that the raised vehicle is securely attached to the lift to prevent the vehicle from slipping, falling, or moving during the installation process.
- DO NOT install any FOX product without the necessary special tools, expertise and chassis lift or you will subject yourself to the risk of SERIOUS INJURY or DEATH. If you elect to not use a chassis lift (which may result in SERIOUS INJURY or DEATH), ensure that the vehicle is: (1) on level ground, (2) that all tires on the ground during installation are blocked to prevent vehicle movement, (3) that at least two tires are on the ground at all times, and (4) that adequately secured jack stands are used to support the vehicle. NEVER get under the vehicle until you have checked to ensure that the vehicle will be stable during installation.
- FOX direct-replacement shocks are designed to fit your vehicle's shock mounts without modification except the reservoir placement on specific models and applications.

FRONT SHOCK INSTALLATION

TOOLS REQUIRED

- Manufacturer Torque Specs
- Torque Wrench
- Blue Loctite
- 7/32" Drill Bit

NOTICE: Medium-strength thread-lock (blue Loctite) is recommended on all bolts.

1. Please read the installation guidelines on page 5 for instructions on how to properly lift and secure the vehicle.

STOCK SHOCK REMOVAL

2. Remove front wheels from vehicle.

3. Remove front stock shocks. It may be necessary to support or raise the vehicle axle for bolt removal and installation of FOX shocks. Do not discard lower mount bolts and nuts. Your new FOX shocks will use them (Fig. 1).



Fig. 1: Remove stock shocks.

RESERVOIR BRACKET INSTALLATION

4. Install the supplied remote reservoir mounting brackets to the vehicle in front of the coil bucket.

4A. Remove the brake line bracket bolt by the side of the coil bucket closest to the front of the vehicle. Do not discard the bolt. It will be used to secure the brake line bracket and shock reservoir bracket (Fig. 2).

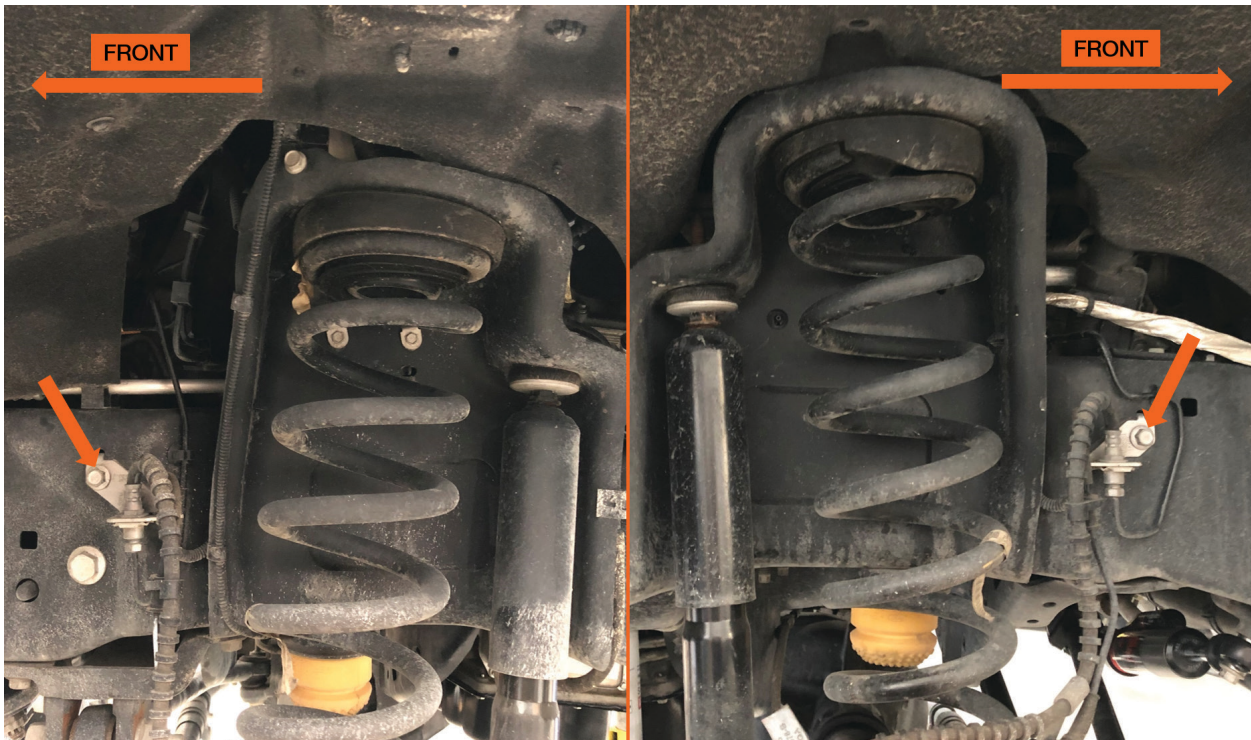

Fig. 2: Remove the brake line bolt.

4B. Pull the brake line bracket away from the chassis frame rail. From the top, slide the Group A or B reservoir bracket in between the two. Make sure the reservoir bracket is mounted behind the brake line and flush against the chassis frame rail.

4C. Utilize the hole on the reservoir bracket to line up the brake line alignment tab with the reservoir bracket. Secure both the brake line and reservoir bracket with the bolt that was removed. Torque to OEM specifications (Fig. 3).



Fig. 3: Align the reservoir bracket with the brake line tab.

4D. Use the bracket to mark the top hole location. Ensure the bracket is secured.

4E. Drill a pilot hole for the Group C self-tapping screw using a 7/32" drill bit and the marked location for the hole.

4F. Secure the bracket using the Group C screw. Ensure proper orientation by checking that the reservoir mounting portion of the bracket has its lowest point toward the front of the vehicle (Fig. 4).

4G. Repeat on both sides of the vehicle.

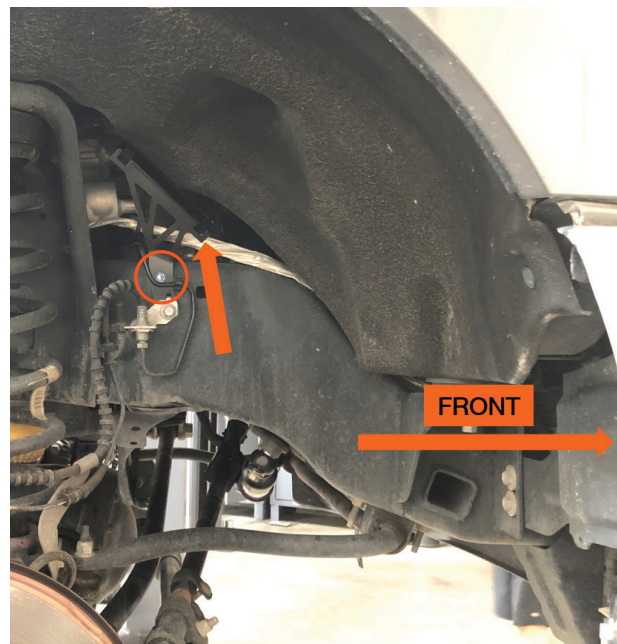

Fig. 4: Secure bracket with Group C screw.

FOX SHOCK INSTALL

5. Connect the FOX shock to the top of the vehicle mount using the provided hardware. Torque to OEM specifications.

6. Connect the FOX shock to the lower mount using the OEM hardware. Torque to OEM specifications.

7. Use the supplied clamps to mount the reservoir to the bracket. Utilize the slots in the bracket to locate the clamps. Do not feed the clamps through the slots in the brackets (Fig. 5).

8. Torque the four socket head cap screws to 19 IN-LBS. The reservoir's DSC adjuster point toward the front of the vehicle once installed (Fig. 6 & 7).

NOTE: The hose must loop back and up above the coil bucket. The reservoir hose fitting sits above the reservoir when installed.



Fig. 5: This image is for informational purposes only to demonstrate how the reservoir brackets should interface with the clamps. **Mount Group A and B brackets to the vehicle before you install the reservoir.**



Fig. 6: Left side hose orientation.



Fig. 7: Right side hose orientation.

9. Repeat steps 5-8 on both sides of the vehicle.

CHECK AND FINAL DETAILS

10. Check that the suspension has proper clearance by steering completely in both directions.

11. Reinstall both front wheels and torque to OEM specifications.

REAR SHOCK INSTALLATION

NOTICE: Medium-strength thread-lock (blue Locktite) is recommended on all bolts.

1. Please read the installation guidelines on page 5 for instructions on how to properly lift and secure the vehicle.

STOCK SHOCK REMOVAL

2. Remove rear wheels from vehicle.

3. Remove rear stock shocks. It may be necessary to support or raise the vehicle axle in order to remove bolts and for installation of new FOX shock. Do not discard bolts and nuts, as they will be used with the FOX shock installation.

FOX SHOCK INSTALL

4. Connect the FOX shock to the top vehicle mount using the provided rubber washer and OEM hardware. Torque to OEM specifications (Fig. 8 & 9).

NOTE: View the images below to correctly orient the left and right rear shocks.



Fig 8: The left side shock must be mounted with the reservoir pointing inward.

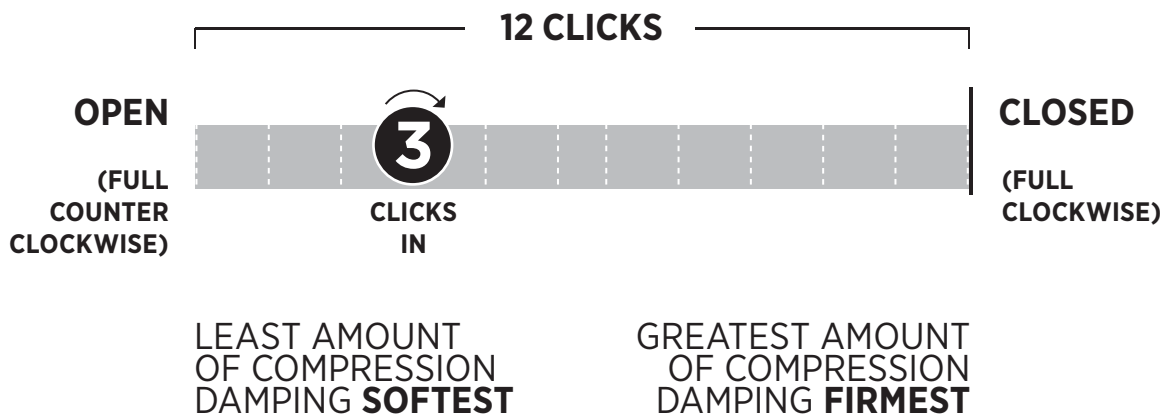

Fig 9: The right side shock must be mounted with the reservoir pointing forward.

FOX FACTORY DSC

DUAL SPEED COMPRESSION (DSC) ADJUSTER SETTINGS

DSC HIGH SPEED COMPRESSION



DSC LOW SPEED COMPRESSION

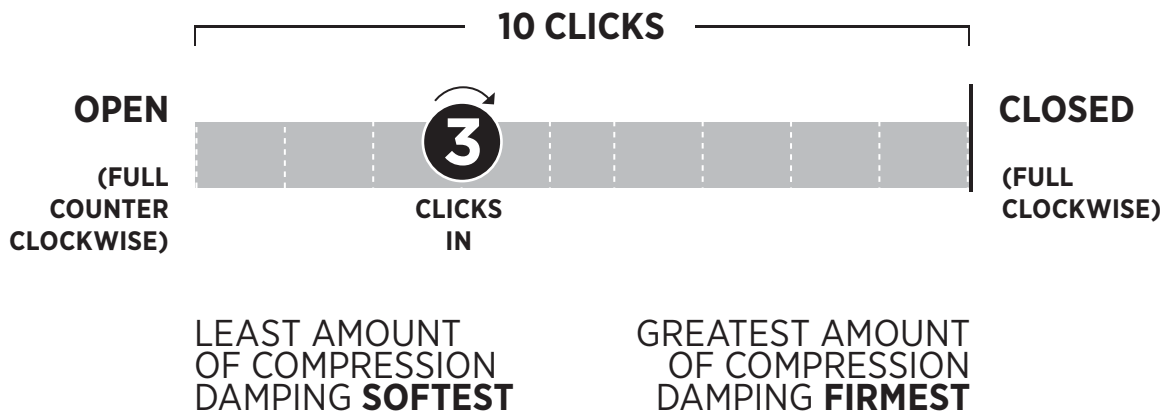

WARRANTY INFORMATION

FOX LIMITED WARRANTY

FOX Factory, Inc., a Georgia corporation having an office at 6634 Highway 53 Braselton, GA 30517 (“FOX”), makes the following LIMITED WARRANTY with respect to its suspension products:
LIMITED ONE (1) YEAR WARRANTY ON SUSPENSION PRODUCTS.

Subject to the limitations, terms and conditions hereof, FOX warrants, to the original retail owner of each new FOX suspension product, that the FOX suspension product, when new, is free from defects in materials and workmanship. Unless otherwise required by law, this warranty expires one (1) year from the date of the original FOX suspension product retail purchase from an authorized FOX dealer or from a FOX authorized Original Equipment Manufacturer where FOX suspension is included as original equipment on a purchased vehicle. If law requires a warranty duration of greater than one (1) year, then, subject to the other provisions hereof, this warranty will expire at the end of the minimum warranty period required by such law.

TERMS OF WARRANTY

This warranty is conditioned on the FOX suspension product being operated under normal conditions and properly maintained as specified by FOX. This warranty is only applicable to FOX suspensions purchased new from an authorized FOX source and is made only to the original retail owner of the new FOX suspension product and is not transferable to subsequent owners. This warranty is void if the FOX suspension product is subjected to abuse, neglect, improper or unauthorized repair, improper or unauthorized service or maintenance, alteration, modification, accident or other abnormal, excessive, or improper use.

Should it be determined by FOX in its sole and final discretion, that a FOX suspension product is covered by this warranty, it will be repaired or replaced, by a comparable model, at FOX’s sole option, which will be conclusive and binding. THIS IS THE EXCLUSIVE REMEDY UNDER THIS WARRANTY. ANY AND ALL OTHER REMEDIES AND DAMAGES THAT MAY OTHERWISE BE APPLICABLE ARE EXCLUDED, INCLUDING, BUT NOT LIMITED TO, INCIDENTAL OR CONSEQUENTIAL DAMAGES OR PUNITIVE DAMAGES.

This limited warranty does not apply to normal wear and tear, malfunctions or failures that result from abuse, improper assembly, neglect, alteration, improper maintenance, crash, misuse or collision. This limited warranty gives the consumer specific legal rights. The consumer may also have other legal rights which vary from state to state or country to country. Some states and countries do not allow the exclusion or limitation of incidental or consequential damages or warranties, and if dictated by law the above limitations or exclusions may not apply to you. If it is determined by a court of competent jurisdiction that a certain provision of this limited warranty does not apply, such determination shall not affect any other provision of this limited warranty and all other provisions shall remain in full effect.

THIS IS THE ONLY WARRANTY MADE BY FOX ON ITS SUSPENSION PRODUCTS AND COMPONENTS, AND THERE ARE NO WARRANTIES WHICH EXTEND BEYOND THE DESCRIPTION HEREIN. ANY WARRANTIES THAT MAY OTHERWISE BE IMPLIED BY LAW INCLUDING, BUT NOT LIMITED TO, ANY IMPLIED WARRANTY OF MERCHANTABILITY OR FITNESS FOR A PARTICULAR PURPOSE ARE EXCLUDED.

SHOCKS NEED LOVE TOO

FOX SERVICE AND UPGRADES

HAVE YOUR FOX SHOCKS SERVICED BY FOX TECHNICIANS. CALL OUR OFF-ROAD AND TRUCK SERVICE CENTER AT 619.768.1800 TO GO OVER THE SERVICE AND UPGRADE OPTIONS AVAILABLE FOR YOUR PRODUCT. ONCE YOU'VE SETUP YOUR SERVICE AND/OR UPGRADES YOU WILL RECEIVE A RETURN AUTHORIZATION NUMBER AND SHIPPING INSTRUCTIONS.

COMPLETE SERVICES

100% street use: every 50,000 miles

50% street/ 50% off-road use: Every 10,000 miles

SERVICE MENUS AND PRICING

visit ridefox.com/service



**WARNING: Cancer and
Reproductive Harm –**
www.P65Warnings.ca.gov

