

S5303

2022-UP TOYOTA TUNDRA, 3.5L,
MUFFLER REPLACEMENT, 3.0"

MBRP®

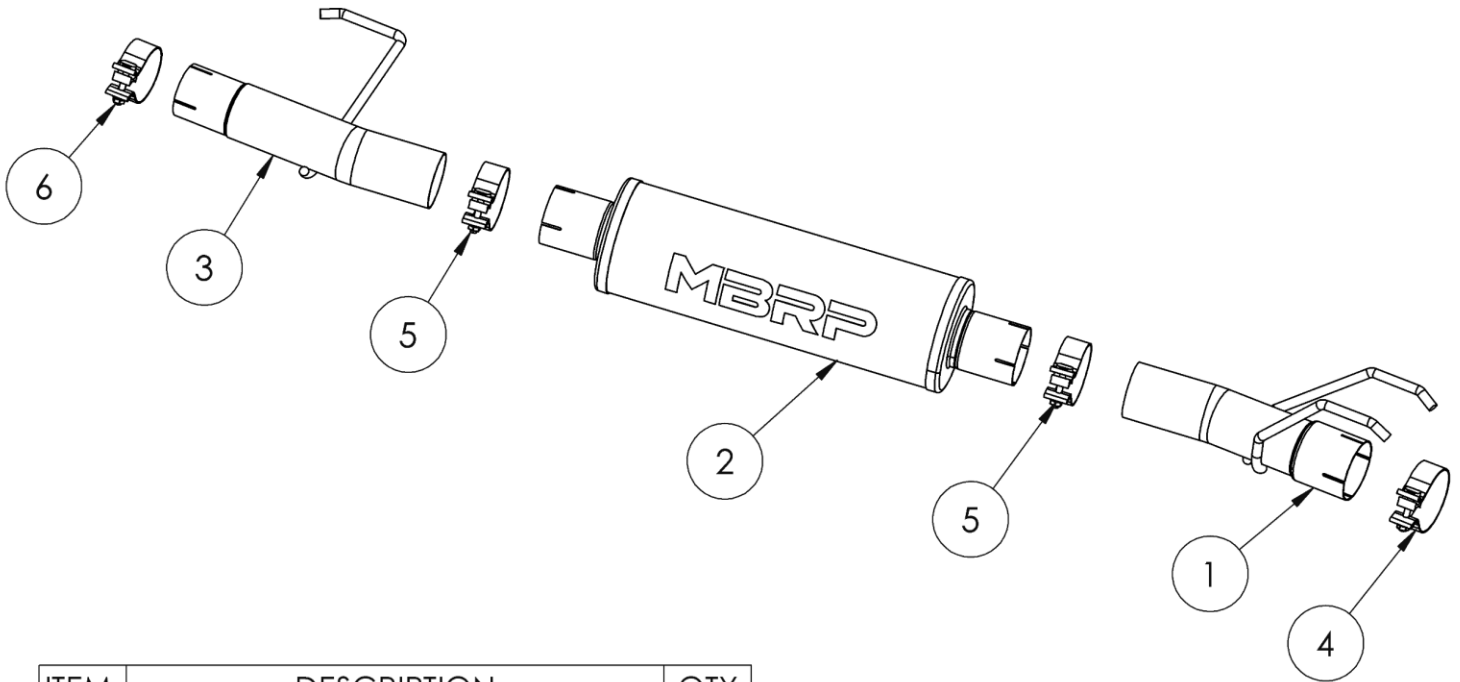

ITEM	DESCRIPTION	QTY
1	FRONT PIPE	1
2	MUFFLER	1
3	REAR PIPE	1
4	3.2" BAND CLAMP	1
5	3.0" CLAMP	2
6	2.75"CLAMP	1

PLEASE READ BEFORE STARTING INSTALLATION

While MBRP has made every effort to ensure that all components of this system are of superior quality and properly packaged, it is the installer's responsibility to ensure the following before removal of the factory exhaust:

- that ALL components shown above are present.
- that ALL mating components fit together.
- that there are no damaged components.
- that the system you have purchased is appropriate for your vehicle year, model and configuration.
- that the system will not interfere with any modifications previously installed or planned.
- that you have read and understand these instructions.

If you have any questions or are uncertain about any aspect of the installation of this system to your vehicle please contact your dealer before commencing installation.

MBRP

Removal of Stock System



Figure 1



Figure 2



Figure 3



Figure 4



Figure 5

1. Apply penetrating lubricant liberally to all exhaust fasteners, hangers, and rubber insulators.
2. Note the approximate location of the factory tail pipe to aid in system alignment during the installation
Refer to Figure 1.
3. Mark and cut the factory over-axle pipe 1" behind the rear muffler flange.
Refer to Figure 2.
4. Mark and cut the factory front pipe 0.75" in front of the muffler body.
Refer to Figure 3.
5. Remove the factory muffler from the rubber insulators.
6. Deburr the cut pipes remaining on the vehicle.

Installation of MBRP Performance Exhaust

1. Using the **3.2" Band Clamp**, loosely install the **Front Pipe** onto the factory front pipe and into the factory rubber insulators.
Refer to Figure 4.
2. Mark the factory over-axle pipe 3" from the cut end. Slide the **2.75" Clamp** and the **Rear Pipe** onto the factory over-axle pipe. Insert the **Rear Pipe Hanger** into the factory rubber insulator.
Refer to Figure 5.
3. Place a **3.0" Clamp** on each end of the **Muffler** and slide the **Muffler** onto the **Rear Pipe**.
Refer to Figure 6.
4. Install the **Muffler** onto the **Front Pipe**. This will require pushing the **Rear Pipe** farther onto the factory over-axle pipe than the final installation position.
Refer to Figure 7.
5. Slide the **Rear Pipe** forward past the mark made in Step 2.
Refer to Figure 5.

MBRP



Figure 6

6. Before completely tightening the system, pull down on the **Rear Pipe Hanger** to ensure it is taking some of the exhaust system's weight. **Refer to Figure 8.**



Figure 7

7. Carefully align the system and tips. Align the edge of each band clamp with the edge of the joint it is connecting. Tighten all hardware and clamps, starting at the front and working rearward to secure the system. Check along the full length of the exhaust system to ensure there is adequate clearance for fuel lines, vent lines, brake lines, frame, bodywork, suspension and any wiring, etc. If there is any interference detected, relocate or adjust to provide adequate clearance. Ensure all clamp connections are secure and components are unable to rotate or slide. Band clamps require approximately 45 lb-ft (60 N-m) of torque. Verify clearances, system security and band clamp torque after 30-60 miles (50-100 km) of driving.



Figure 8



Congratulations! You are ready to begin experiencing the improved power, sound and driving experience of your **MBRP** Performance Exhaust. We know you will enjoy your purchase!