

S5263

2017-2020 FORD F150 RAPTOR,
3.5L ECOBOOST, CAT-BACK, 3.0"
DUAL REAR, RACE VERSION

MBRP®

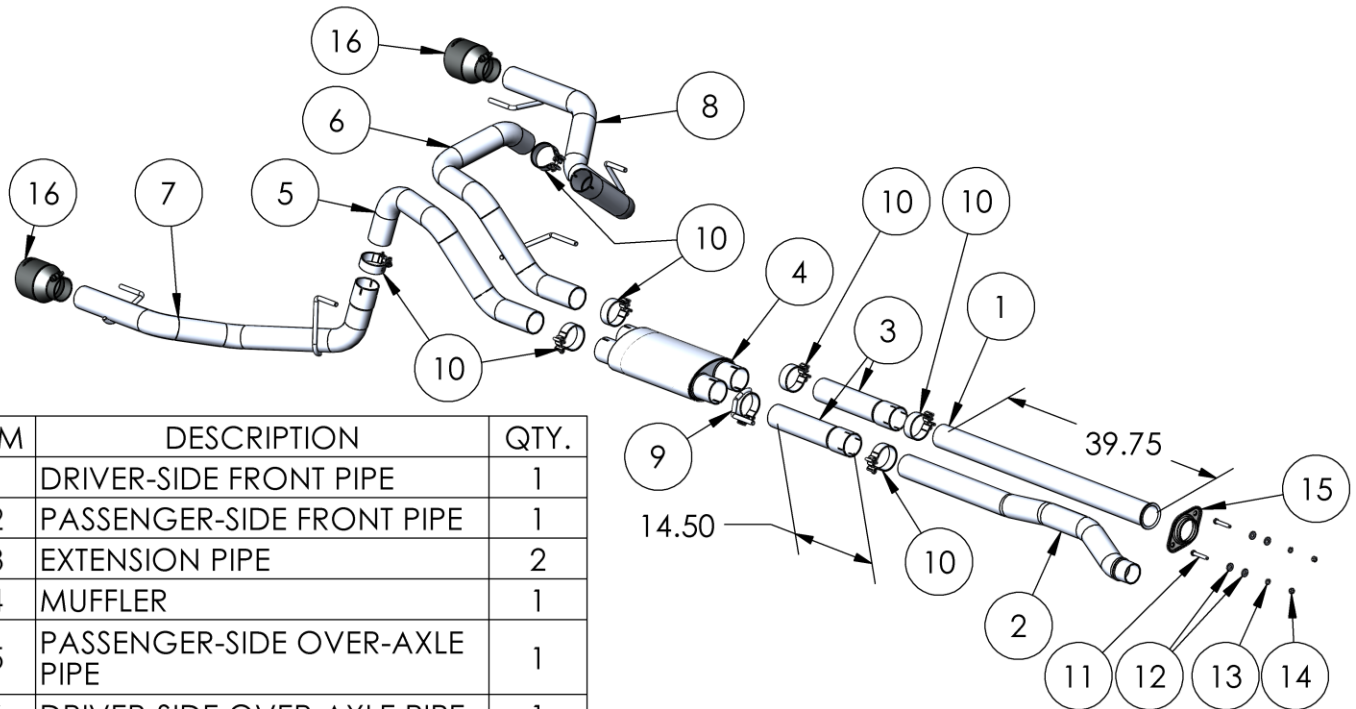

ITEM	DESCRIPTION	QTY.
1	DRIVER-SIDE FRONT PIPE	1
2	PASSENGER-SIDE FRONT PIPE	1
3	EXTENSION PIPE	2
4	MUFFLER	1
5	PASSENGER-SIDE OVER-AXLE PIPE	1
6	DRIVER-SIDE OVER-AXLE PIPE	1
7	PASSENGER-SIDE TAIL PIPE	1
8	DRIVER-SIDE TAIL PIPE	1
9	MUFFLER HANGER CLAMP	1
10	3.0" CLAMP	7
11	3/8" LOCK WASHER	2
12	3/8" FLAT WASHER	4
13	HEX BOLT 3/8X2.5"	2
14	3" FLANGE	1
15	3/8" HEX NUT	2
16	TIP	2

PLEASE READ BEFORE STARTING INSTALLATION

While MBRP has made every effort to ensure that all components of this system are of superior quality and properly packaged, it is the installer's responsibility to ensure the following before removal of the factory exhaust:

- that ALL components shown above are present.
- that ALL mating components fit together.
- that there are no damaged components.
- that the system you have purchased is appropriate for your vehicle year, model and configuration.
- that the system will not interfere with any modifications previously installed or planned.
- that you have read and understand these instructions.

If you have any questions or are uncertain about any aspect of the installation of this system to your vehicle please contact your dealer before commencing installation.

MBRP®

Removal of Stock System:



Figure 1

1. Apply a penetrating lubricant liberally to all hangers, hardware and rubber isolators and lower the spare tire to provide clearance for removing the factory tail-pipes.

2. Remove tip hangers from vehicle, both sides.

Refer to Figure 1.

3. Loosen the factory tail-pipe clamps and pry open the factory spring locks.

Refer to Figure 2.

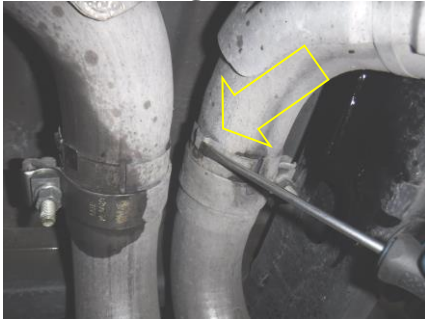

Figure 2

4. Remove the tail-pipes from the vehicle. You may need to remove the driver-side isolator from the frame.

5. Loosen the two clamps ahead of the muffler. Remove the factory muffler assembly from the hangers and remove from the vehicle.

Refer to Figure 3.



Figure 3

6. Remove the factory front resonator bolts and loosen the sleeve clamp nuts. Remove the factory front resonator from the vehicle.

Refer to Figure 4.

Installation of MBRP Performance Exhaust:

1. Loosely install the **Passenger-Side Front Pipe** using the factory coupler clamp. You can modify the coupler to have the nuts facing down by adding a notch in the clamp to the side opposite the factory notch.

Refer to Figure 5.

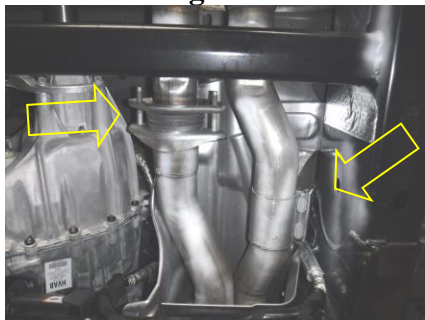

Figure 4

2. Loosely install the **Driver-Side Front Pipe** using the supplied **Flange** and **3/8" Hardware**.

Refer to Figure 5.

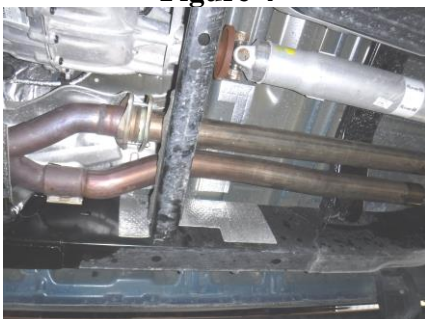

Figure 5



Figure 6

3. ONLY SuperCrew models require the two **Extension Pipes** to be installed onto the **Front Pipes** using **3” Clamps**. (SuperCrew model shown.)

Refer to Figure 6.

4. Place the **Muffler Hanger Clamp** onto the outer **Muffler** inlet and one **3” Clamp** onto the **Driver-Side Front Pipe** (or **Extension Pipe** if required).

Refer to Figure 7.



Figure 7

5. Install the **Muffler** onto the pipes and the **Muffler Hanger Clamp** into the factory rubber isolator at the same time.

Refer to Figure 8.

6. Using a **3” Clamp**, install the **Driver-Side Over-Axle Pipe** into the **Muffler** and into the factory isolator.

Refer to Figure 9.



Figure 8

7. Install **Driver-Side Tail Pipe** onto the **Driver-Side Over-Axle Pipe** and into the factory isolator on the frame. It may be necessary to remove the factory isolator from the frame if not done so during system removal. Reinstall the frame and tail factory isolators.

Refer to Figure 10.

8. Using a **3” Clamp**, very loosely (do not tighten clamp) install the **Passenger-Side Tail Pipe** onto the **Passenger-Side Over-Axle Pipe** and install into the **Muffler** (using a **3” Clamp**) and the factory isolator on the frame as an assembly. Place the rear hanger into the rear factory isolator and reinstall on the vehicle.

Refer to Figures 11 and 12.



Figure 9



Figure 10

MBRP®



Figure 11



Figure 12



Figure 13

9. Install the **Exhaust Tips** and align them with the bumper opening ensuring there is clearance around the body, frame, and bumper. **Refer to Figure 13.**

10. Raise the spare tire into position.

11. Align the edge of each band clamp with the edge of the joint it is connecting. Tighten all hardware and clamps, starting at the front and working rearward to secure the system. Check along the full length of the exhaust system to ensure there is adequate clearance for fuel lines, vent lines, brake lines, frame, bodywork, suspension, and any wiring, etc. If there is any interference detected, relocate, or adjust to provide adequate clearance. Ensure all clamp connections are secure and components are unable to rotate or slide. Band clamps require approximately 45 lb-ft (60 N-m) of torque. Verify clearances, system security and band clamp torque after 30-60 miles (50-100 km) of driving.



Congratulations! You are ready to begin experiencing the improved power, sound and driving experience of your **MBRP** performance exhaust system. We know you will enjoy your purchase.