

# 16-18 TOYOTA TACOMA V6

**CORSA**<sup>®</sup>  
PERFORMANCE



## IMPORTANT! WARRANTY AND INSTALLATION INSTRUCTIONS

*Please Forward All Information to Consumer*

Be sure to review the enclosed instructions prior to beginning the installation process. If you have any questions about the enclosed parts or instructions, or if you encounter a problem during installation:

**CALL TECHNICAL SUPPORT:** 440.891.0999 or 800.486.0999

**TO ACTIVATE YOUR WARRANTY GO TO:  
[CORSAPERFORMANCE.COM/WARRANTY](http://CORSAPERFORMANCE.COM/WARRANTY)**

COLOR INSTRUCTIONS ARE AVAILABLE BY PART NUMBER ON: [CORSAPERFORMANCE.COM](http://CORSAPERFORMANCE.COM)



**NEVER work on a hot exhaust system.**  
Allow time for the vehicle to cool.

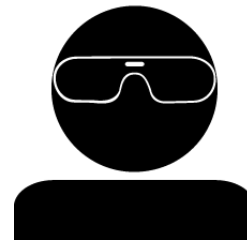

**Always wear eye protection**  
when working under a vehicle.

**INSTALL DIFFICULTY** 

### RECOMMENDED TOOLS & SUPPLIES

- 3/8" Ratchet
- 15mm Socket
- Soap and Water Solution
- Penetrating Lubricant
- 14mm Socket
- Grommet Pullers or Similar Device
- Torque Wrench

# 2016-2018 TOYOTA TACOMA V6

3.0" Cat-Back; Single Side Exit with Single 4.0" Straight Cut Tip.

Part #: 14917, 14917BLK



## Please take time to read and understand these installation instructions.

CORSA recommends that the installation of this system be performed by a qualified service center or professional installer who has the necessary equipment, tools, and experienced personnel. However, if you decide to perform this installation yourself, the use of an additional person may be required.

**WARNING:** Never work on a hot exhaust system. Allow time for the vehicle to cool. Always wear eye protection when working under a vehicle.

CORSA Performance makes no representation or warranty, expressed or implied that its downpipe or header products and or components there-in comply with federal, state or local emission levels, noise levels, or safety standards or that any of their parts conform with the racing vehicles exemption, unless otherwise noted. The purchaser assumes all responsibility for such use and compliance.

This warranty does not extend to damaged or defect in the finish of a product or to any product, that in the opinion of CORSA Performance, has been misused, damaged by accident or negligence, altered or modified in any way, faulty installation or installed contrary to CORSA installation instructions, or repaired by an unauthorized service facility.

Full warranty available on [www.corsaperformance.com](http://www.corsaperformance.com)

### **Please confirm that all parts are present according to the bill of materials before beginning the installation.**

If something is missing call Tech Support at 440.891.0999 or Toll Free: 1.800.486.0999

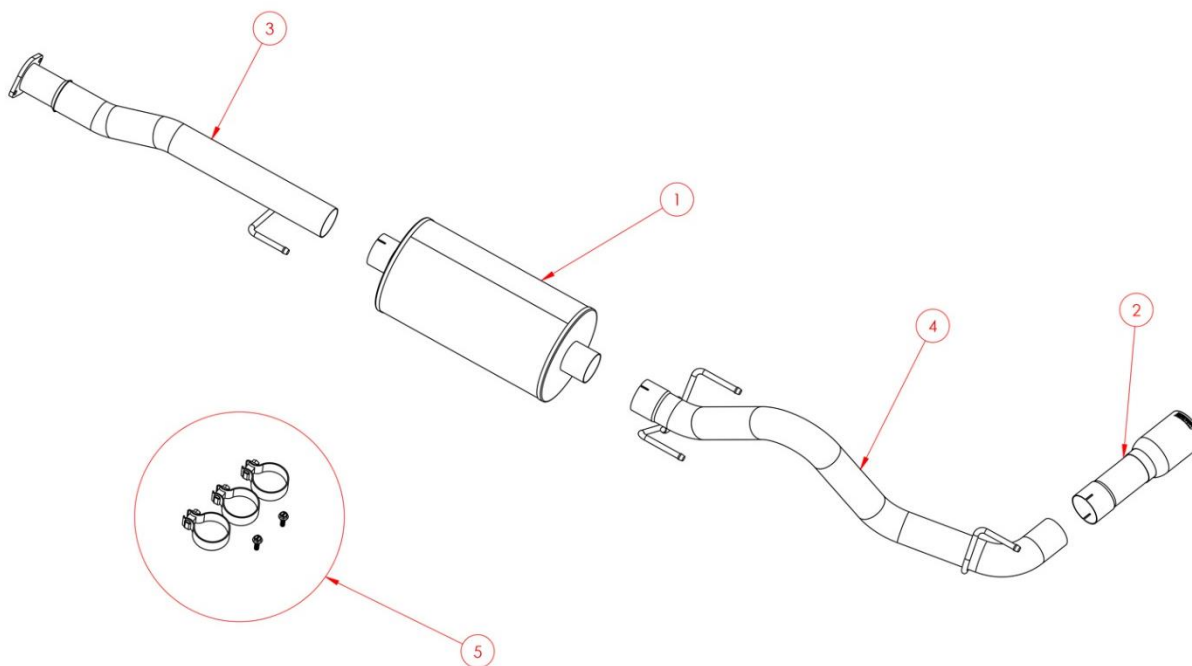

## BILL OF MATERIALS

1.	Muffler (25TC2000)	2.	Tip Assembly (25TC3000)
3.	Head Pipe (25TC4000)	4.	Tailpipe (25TC4004)
5.	Hardware Kit (25TC7004)		

**CAUTION:** Never work on a hot exhaust system. Allow the vehicle to cool for at least an hour and a half. Always wear eye protection when working under a vehicle. It is recommended to use cotton gloves in order to protect stainless steel surfaces from permanent grease and oil stains.

## REMOVAL INSTRUCTIONS

### FACTORY EXHAUST



1. Loosen and remove the two retaining bolts that secure the muffler inlet flange using a 3/8" ratchet and a 14mm socket. The bolts will not be reused.

**NOTE:** Penetrating lubricant may make this step easier.



2. Support the front of the system using a jack stand or similar device.

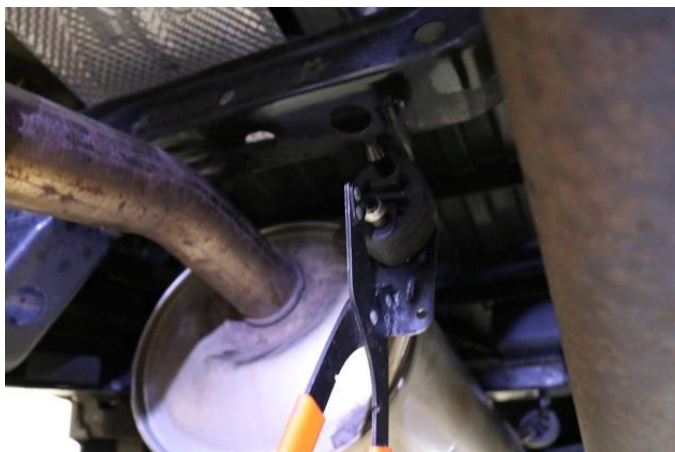

3. Using a soap and water solution spray all four factory hanger grommets. (3 near muffler, 1 on tail pipe near exit).



Remove the three muffler hangers from the factory hanger grommets using grommet pullers or similar device.

**WARNING:** At this point, the exhaust is only supported by the jack stand and the hanger near the tip. Take care not to let the exhaust system tip or roll as it may damage the vehicle and/or cause personal injury.

Continued on Next Page . . .

**REMOVAL INSTRUCTIONS**

**FACTORY EXHAUST**



- 4.** Use grommet pullers to remove the tail pipe hanger near the tip.



- 5.** Carefully remove the factory exhaust system from the vehicle by pulling the exhaust system forward through the chassis, rotating it as needed to clear the suspension, rear axle, and spare tire.

**NOTE:** The factory gasket at the flange connection will be reused for **Install Step 1**.

**Step 5** concludes the removal of the factory exhaust.



### WARNING! DO NOT SKIP THIS STEP!

Apply the anti-seize lubricant (*supplied*) to the threads **ONLY** of all the clamps and flange bolts. Failure to follow this procedure can cause nuts to seize on clamps and potentially destroy threads.

After applying anti-seize lubricant, be sure to **thoroughly** clean your hands, as lubricant will tarnish stainless steel.

All clamps should be tightened using a properly calibrated Torque Wrench. Using an air impact gun will damage the clamp and reduce its ability to effectively seal the joint. It may also cause the joint to separate, thereby causing damage to your exhaust system and to your vehicle.

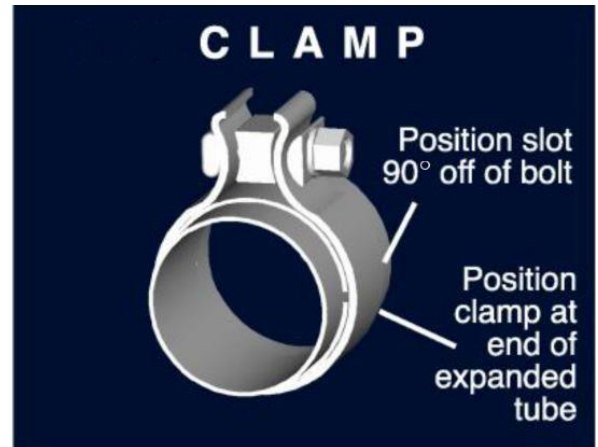

**NOTE:** Align all clamps so that the center of the clamp bolt is 90 degrees from the notch in the pipe.

### INSTALLATION INSTRUCTIONS

CORSA EXHAUST



1. Locate the two supplied M10 bolts and CORSA head pipe assembly. Verify that the factory flange gasket is in place. Insert the head pipe hanger into the factory grommet, then align the head pipe flange with the stock flange, and secure with the supplied bolts. Tighten the bolts with a 14mm socket and 3/8" drive ratchet.



2. Locate a 3.0" clamp and the CORSA muffler assembly. Install the clamp on the inlet end of the muffler assembly, then slide the expanded inlet end of the muffler assembly over the outlet end of the head pipe. Snugly tighten the clamp using a 15mm socket and 3/8" drive ratchet.

**WARNING:** The drain holes on the bottom of the muffler must be on the bottom when it is installed.

**NOTE:** Place a jack stand or similar device for support.

Continued on Next Page ...

## INSTALLATION INSTRUCTIONS

CORSA EXHAUST



- 3.** Install a 3.0" clamp on the inlet end of the CORSA tail pipe assembly, then feed the tail pipe over the rear axle in the vehicle. Insert the front and rear hangers into their corresponding rubber grommets, slide the expanded inlet end of the tailpipe onto the outlet end of the rear muffler. Adjust the tailpipe so the outlet end is parallel and level with the ground. Snug clamp using 15mm socket and 3/8" drive ratchet.



- 4.** Locate the last 3.0" clamp and the CORSA tip assembly. Slide the clamp over the expansion and then slide the expanded end of the tip assembly onto the tail pipe outlet. Adjust rotation of tip until the CORSA logo is facing upwards. Snugly tighten the clamp using a 15mm socket and 3/8" drive ratchet.



- 5.** Ensure the exhaust system is adjusted properly. Make sure all hangers have clearance, the tailpipe is not contacting the rear axle or chassis, and the tip is adjusted to preference. Begin at the front of the vehicle and fully tighten all bolts and clamps using a torque wrench. Tighten the bolts securing the flange using a 14mm socket to 22 Ft-Lbs, the three 3" clamps to 45 Ft-lbs using the 15mm socket.

**NOTE:** During cold weather start-ups, you may experience an exhaust sound that is deeper and louder in tone than usual. This is temporary and will diminish to normal levels once your engine has reached its normal operating temperature.

**NOTE:** Immediately following the installation of your exhaust system, you may experience a trace of smoke after initial start-up. DO NOT be alarmed. The smoke is caused by the burning of a small amount of forming oil residue used in the manufacturing process.

**NOTE:** It is strongly suggested that all clamps be checked and tightened after road testing the vehicle once the system has cooled.